

RIDING TROWEL

MSP455



SAFETY & OPERATIONS MANUAL

Manual Part #: 075706 | Revision: B
Language: English | Original Instructions



NOTICE

This manual, or a copy of it, must be kept with the machine at all times.
There is a manual storage container located on the machine for your convenience.

RIDING TROWEL

Safety and Operations MANUAL

This manual covers the Riding Trowel model listed below:

<u>Part No.</u>	<u>Description</u>
071100	RIDER, MSP455X

Copyright © 2021 Allen Engineering Corporation
All rights reserved

All information, specifications, and illustrations in this manual are subject to change without notice and are based on the latest information at the time of publication. No part of this manual may be reproduced or transmitted in any form or by any means, electronics or mechanical, for any purpose, without the express written permission of Allen Engineering Corporation (AEC). AEC assumes no responsibility or liability for any errors or inaccuracies that may appear in this manual.

Allen® Products are covered under one or more of the following patent numbers:

U.S. Design Patents: 344,736; 400,542; 400,544; 402,998; 402,999; 403,332; 404,041; 404,042; 410,931; 413,127; 416,564; 465,897; 466,909; 474,203.

U.S. Utility Patents: 5,108,220; 5,238,323; 5,328,295; 5,352,063; 5,405,216; 5,476,342; 5,480,257; 5,480,258; 5,533,831; 5,562,361; 5,567,075; 5,613,801; 5,658,089; 5,685,667; 5,803,658; 5,816,739; 5,816,740; 5,890,833; 5,934,823; 5,967,696; 5,988,938; 5,988,939; 6,019,433; 6,019,545; 6,048,130; 6,053,660; 6,089,786; 6,106,193; 6,857,815; 5,288,166; 6,582,153 B1, 7,108,449; 7,114,876; 7,316,523; 7,690,864 B2

Canadian Patents: 2,039,893.

With other Patents Pending.

Printed in U.S.A.

Sect No.	Title	Page
	General Information	4
	Limited Warranty	6
	Information Contained in this Manual	7
	Dealer Information.....	8
	Ordering Parts	9
	Model Number / Serial Number Codes.....	10
	Unit Identification	11
	Technical Specifications	12
	Machine Dimensions	13
	Engine Breakdown	14
	Engine Specifications	15
	CE Declaration	16
	Sound & Vibration Testing.....	17
1	SAFETY	18
	Federal / State Warning Regulations	19
	Manual Tag Safety Detail	20
	Spark Arrestor Notice	21
	Operating Safety	22
	Engine Safety	23
	Service Safety	24
	Lifting Safety	25
	Transportation Safety	27
	Pan Installation, Lifting Bridal	29
	Pan Installation, Dolly Jacks	30
2	OPERATION.....	31
	Introduction to MSP455.....	32
	Start-up Procedure.....	33
	Trowel Operation - Operator Controls	34
	Trowel Operation.....	35

Sect No.	Title	Page
3	SERVICE	38
	Periodic Maintenance Schedule.....	39
	Troubleshooting.....	40
	Gearbox Maintenance.....	42
	Pressure Plate and Driveline Maintenance.....	43
	Drive Belt Maintenance	44
	Lift Lever Adjustment	48
	Transporting the Trowel	50
	Battery - Jump Start.....	52
	Retardant System - Winterizing	54
	Cleaning Procedure	56
	Accessories.....	57
	Parts Manual	58
	Revision Detail	59

Allen Engineering Corporation (“Allen”) warrants its products to be free of defects in material or workmanship for:

TWO YEARS FROM END USER’S DATE OF PURCHASE

Warranty period begins on the date of purchase by the End User of the product. All warranty is based on the following limited warranty terms and conditions, including the disclaimer of implied warranties and consequential damages.

1. Allen’s obligation and liability under this warranty is limited to repairing or replacing parts if, after Allen’s inspection, there is determined to be a defect in material or workmanship. Allen reserves the choice to repair or replace.
2. If Allen chooses to replace the part, it will be at no cost to the customer and will be made available to the Allen Distributor, Dealer, or Rental Center from whom the End User purchased the product.
3. Replacement or repair parts, installed in the product, are warranted only for the remainder of warranty period of the product as though they were the original parts.
4. Allen does not warranty engines or batteries. Engine warranty claims should be made directly to an authorized factory service center for the particular engine manufacturer. Batteries are not warranted due to unknown treatment during transport, etc, and any battery claims should be directed to the battery manufacturer.
5. Allen’s warranty does not cover the normal maintenance of products or its components (such as engine tuneups and oil & filter changes). The warranty also does not cover normal wear and tear items (such as belts and consumables).
6. Allen’s warranty will be void if it is determined that the defect resulted from operator abuse, failure to perform normal maintenance on the product, modification to product, alterations or repairs made to the product without the written approval of Allen. Allen specifically excludes from warranty any damage to any trowels resulting from an impact to the rotors.
7. Impact damage to gear boxes is not covered under the Allen warranty and is deemed customer abuse.
8. Allen will pay shop labor on warranty items at the Allen Shop Labor Rate in existence on the date of the warranty claim. An Allen labor chart will determine the time allowed to complete a repair and will govern the shop labor hours that will be allowed.
9. Allen will pay freight on warranty replacement parts at worldwide standard ground rates. No warranty replacement parts will be shipped air freight at the expense of Allen. Allen only pays outbound freight charges when sending warranty replacement parts to the customer via ground service. Allen does not pay any inbound freight. However, if Allen determines this to be a warranted item, only then will Allen reimburse the customer for inbound freight at standard ground rates.
10. ALLEN ENGINEERING CORPORATION’S WARRANTY POLICY WILL NOT COVER THE FOLLOWING: TAXES; SHOP SUPPLIES; ENVIRONMENTAL SURCHARGES; AIR FREIGHT; TRAVEL TIME; LOSS OF TIME; INCONVENIENCE; LOSS OF RENTAL REVENUE; RENTAL COSTS OF EQUIPMENT USED TO REPLACE THE PRODUCT BEING REPAIRED; LOSS OF USE OF THE PRODUCT; COMMERCIAL LOSS; OR ANY OTHER CHARGES WHATSOEVER OR ANY LIABILITIES FOR DIRECT, INCIDENTAL, OR CONSEQUENTIAL DAMAGE OR DELAY.
11. ALLEN ENGINEERING CORPORATION MAKES NO OTHER WARRANTY, EXPRESSED OR IMPLIED. THIS LIMITED WARRANTY IS IN LIEU OF THE WARRANTY OF MERCHANTABILITY AND FITNESS. THERE ARE NO OTHER WARRANTIES THAT EXTEND BEYOND THE DESCRIPTION ON THIS DOCUMENT.
12. No Allen employee or representative is authorized to change this warranty in any way or grant any other warranty unless such change is made in writing and signed by an officer of Allen Engineering Corporation.



This manual provides information and procedures to safely operate and maintain the Allen Machine.

For your own safety and protection from personal injury, carefully read, understand, and observe the safety instructions described in this manual. Keep this manual or a copy of it with the machine at all times.

Always operate this machine in accordance with the instructions described in this manual. A well maintained piece of equipment will provide many years of trouble free operation.

This manual is divided into the following sections:

**SECTION 1
SAFETY**

**SECTION 2
OPERATIONS**

**SECTION 3
SERVICE**

Complete any warranty requirements as specified by the engine manufacturer in their instructions found inside the manual box located on the operator's right side of the machine under the seat frame.

Your engine and clutch are not manufactured by Allen Engineering Corporation, Inc, and therefore is not covered under Allen Engineering Corporation, Inc warranty.

Your engine manufacturer should be contacted if you wish to purchase a parts manual or a repair manual for your engine.

Refer to enclosed Owner's engine manual for complete O&M instructions. See your battery manufacturer for battery warranty.

General Information

Dealer Information

Your Dealer has Allen Engineering Corporation trained mechanics and original Allen replacement parts. Always contact the Allen Dealer who sold you this machine for Allen Certified repairs and replacement parts.

Place Allen Dealer information below for future reference.

Dealer Name: _____

Phone #: (____) - ____ - _____

Address: _____

City: _____ **State:** _____ **Zip:** _____

Salesman: _____ **Mobile Phone:** _____

Additional Comments: _____

The Parts and Decals manual contains illustrated parts lists for help in ordering replacement parts for your machine. Follow the instructions below when ordering parts to insure prompt and accurate delivery:

1. All orders for service parts must include the serial number for the machine. Shipment will be delayed if this information is not available.
2. Include correct description and part number from the PARTS & DECALS manual.
3. Specify exact shipping instructions, including the preferred routing and complete destination address.
4. **DO NOT** return parts to AEC without receiving written authorization from AEC. All authorized returns must be shipped pre-paid.
5. When placing an order, please contact the AEC dealer nearest you.



ALL INFORMATION, SPECIFICATIONS, AND ILLUSTRATIONS IN THIS MANUAL ARE
SUBJECT TO CHANGE WITHOUT NOTICE AND ARE BASED ON THE LATEST
INFORMATION AT THE TIME OF PUBLICATION.

Manufacturer's Codes:

When ordering parts or requesting service information, you will always be asked to specify the model and serial numbers of the machine. The legends below specifically defines each significant character or group of characters of the Model Number and Serial Number codes.

Model Number

MSP 455

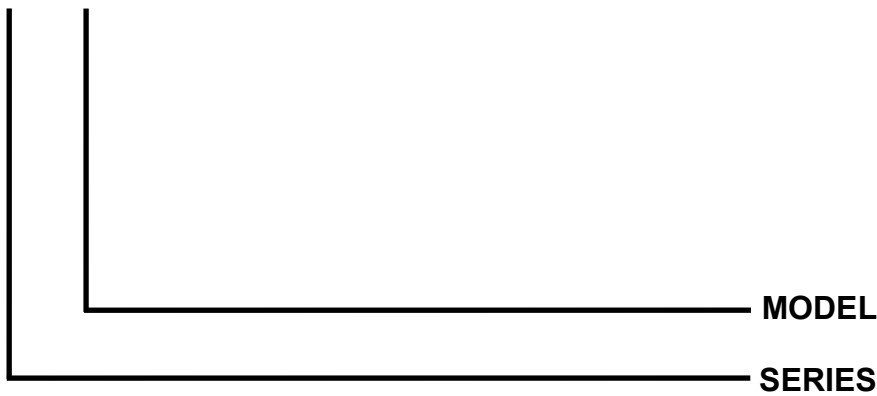

Serial Number

The serial number found on the identification plate is a ten digit format. The model number identifies your machine and will ensure that you receive the correct replacement parts.

455 02 13 001

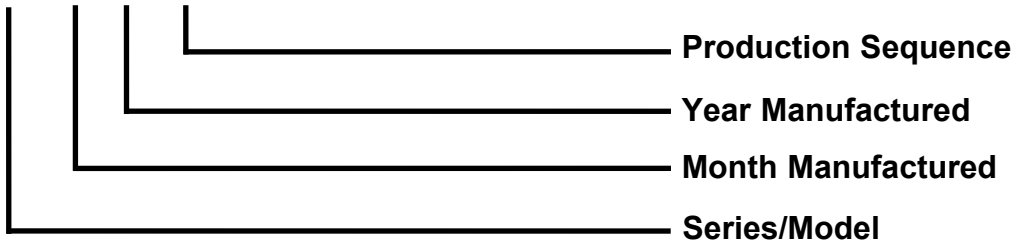

Unit Identification Plate Location:

An identification plate listing the model number and the serial number is attached to each unit and is located on the front side of the mainframe. The serial number and model number location are shown below. This plate should not be removed at any time.

Please record the information found on this plate below so it will be available should the identification plate become lost or damaged. When ordering parts or requesting service information, you will always be asked to specify the model and serial numbers of the machine.

FILL IN FOR FUTURE REFERENCE

Model Number: _____

Serial Number: _____

Date Purchased: _____

Purchased From: _____

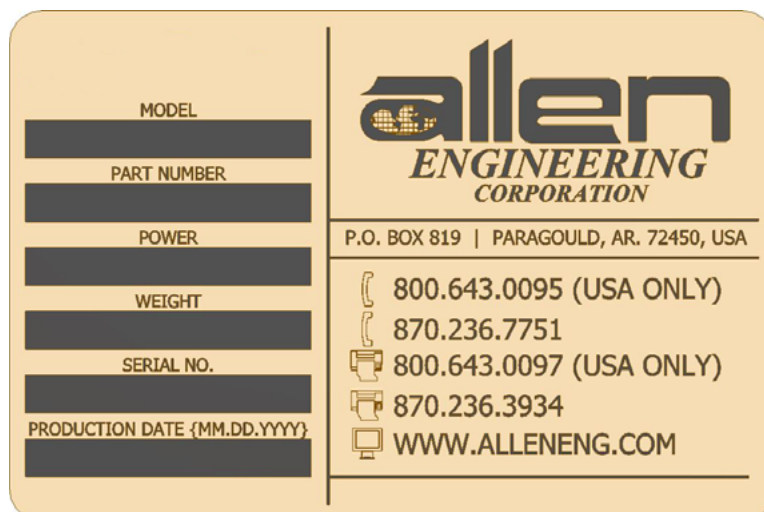

Measurements in this manual are in U.S. units and their customary metric units (i.e., metric units contained within brackets [cm]). The machine RIGHT-HAND and LEFT-HAND sides are determined by sitting on machine (SOM) facing in the direction the machine will travel when going forward.

Machine Features:

- Dimensions - NOL (L x W x H) inch [cm] 101.5 x 50.5 x 60.8
 • (guard rings/top of seat).....[257.8 x 128.3 x 154.4]
- Weight lb [kg] 1,338 [606.9]
- Panning Path Width inch [cm].....97.5 [248]
- Two Rotors (Diameter) inch [cm].....46 [116.8]
- Maximum Rotor Speed (RPM)..... 185
- Finish Blade (10) inch [cm]6 x 18 [15x45]
- Gearbox (2)..... Super Heavy Duty (SHD)
- Welded Guard Ring Standard
- Flip-Up Seat Frame..... Standard
- Operator Control Panel..... Standard
- Powered Retardant Spray System Standard
- Spray System Capacity gal [L].....7 [26.5]
- Steering System..... Power
- Gearbox Rotation..... Standard
- Battery..... 12 V
- Safety Shutdown Switch Operator Seat
- Fuel Capacity gal [L]7 [26.5]
- Run Time (Approximate) hr2.5
- Transmission Type..... Continual Variable Transmission (CVT)
- Drive Belt Type Kevlar Cogged Vee
- Hour Meter TypeDigital Read-out

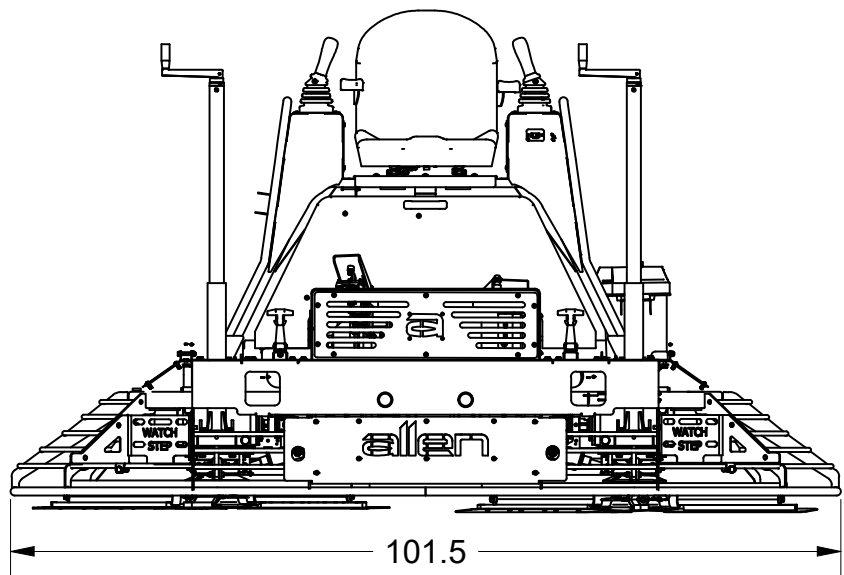
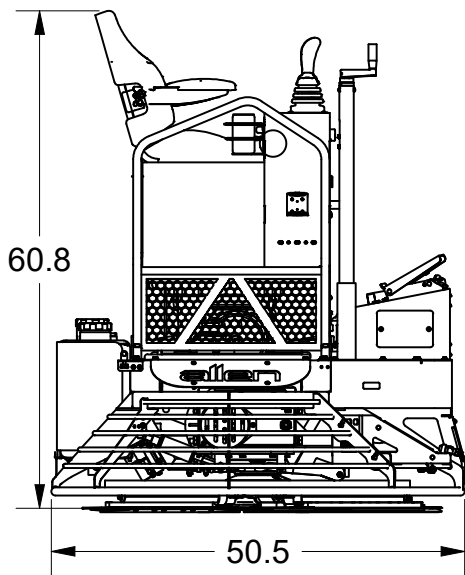

General Information

Engine Breakdown

The Information below was taken directly from the manufactures product literature. For further information please reference the engine manufactures Owner's Manual and Service manual.

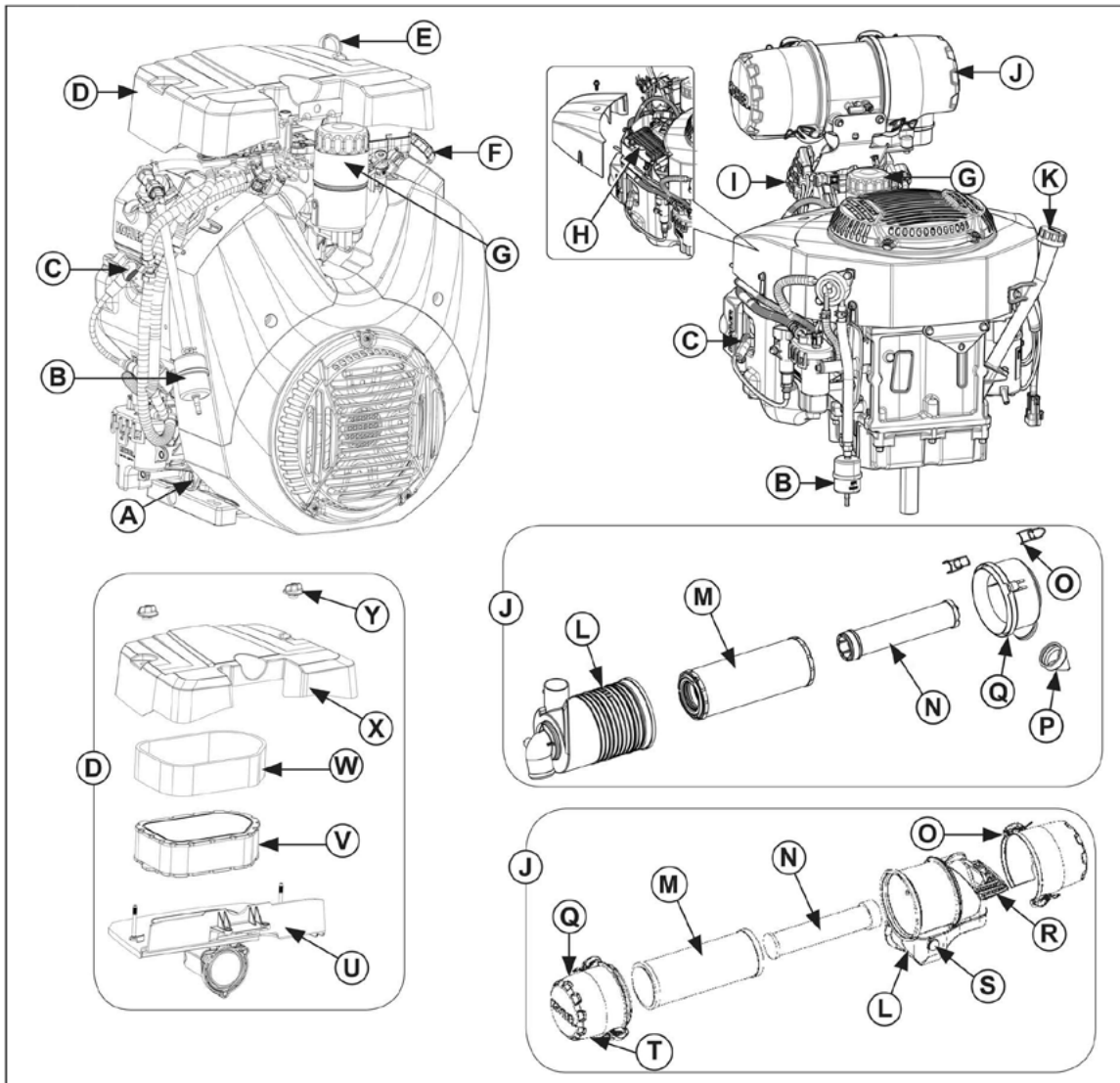

A	Oil Drain Plug	B	Fuel Filter	C	Spark Plug	D	Low-Profile Air Cleaner
E	Dipstick	F	Oil Fill	G	Oil Filter	H	Oil Cooler
I	Fuses	J	Heavy-Duty Air Cleaner	K	Oil Fill/Dipstick	L	Air Cleaner Housing
M	Element	N	Inner Element	O	Retaining Clip	P	Dust Ejector Valve
Q	End Cap	R	Inlet Screen	S	Plug or Filter Minder	T	Ejector Area
U	Air Cleaner Base	V	Paper Element	W	Precleaner	X	Air Cleaner Cover
Y	Air Cleaner Knob	Note: Refer to the left side of this figure for information about the Kohler ECH980 engine.					

Engine Information

Your MSP455X Riding Trowel is equipped with a liquid cooled 38 HP Kohler gasoline engine. Refer to the applicable engine OEM Owner's manual for specific instructions regarding engine operation. This manual is included with the riding trowel at the time of shipping from AEC.

Engine Features:

Model Number:	Command PRO EFI ECH980
Fuel Type.....	Gasoline
Max Power @3600 RPM hp (kW).....	38 (28.3)
Displacement cu in (cc)	61 (999)
Bore in (mm)	3.5 (90)
Stroke in (mm).....	3.1 (78.5)
Peak Torque @ Maximum lbs ft (Nm)	61.5 (83.4)
Compression Ratio.....	8.8:1
Dry Weight lbs (kg)	132 (60)
Oil Capacity U.S. quarts (L)	2.0 (1.9)
Lubrication	Full pressure w/full-flow filter
Dimensions L x W x H in.....	15.8 x 19.1 x 23.6

Engine Oil

Recommended oil: Kohler PRO 10W-50 Synthetic (2 Qts)

Alternative oils must be API service class SJ or higher.

- Change the type of engine oil according to the ambient temperature. See figure below.
- When using oil of different brands from the previous one, be sure to drain all the previous oil before adding the new engine oil.
- For general use 10W/30 oil is recommended (2 Qts).

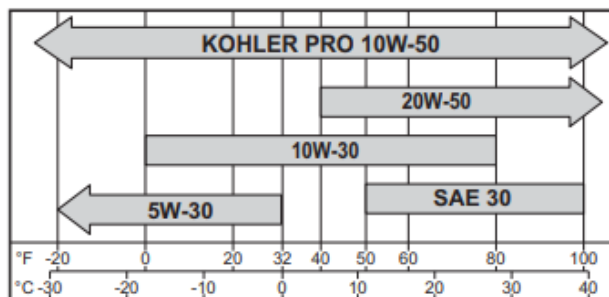

PENDING CE DECLARATION AT THIS TIME.



Sound Pressure Level Information:

Sound pressure is “A” weighted . Measured at the operators ear position while the ride-on trowel is operating at full throttle on concrete in a manner most often experienced in “normal ” circumstances. Sound pressure may vary depending upon the condition of the concrete. Hearing protection is always recommended.



Vibration Level Information:

The vibration level indicated is the average value obtained at the handle grips and the seat while operating the ride-on trowel on hard concrete in a manner most often experienced in “normal” circumstances. Values were obtained from all three axes of motion. The values shown represent the AVERAGE value from these measurements.

Summary Data Of Sound And Vibration Testing for CE Marking					
Test Machine	Engine Type	Sound Level (db)	Seat Vibration (m/s ²)	Right Hand Vibration (m/s ²)	Left Hand Vibration (m/s ²)
MSP455X	Kohler 38 hp	92	0.122	1.233	0.735
This information was acquired from sound and vibration analysis tests conducted at Allen Engineering Corporation test facilities.					

SECTION 1: SAFETY



RESPIRATORY HAZARDS

Grinding/cutting/drilling of masonry, concrete, metal and other materials can generate dust, mists and fumes containing chemicals known to cause serious or fatal injury or illness, such as respiratory disease, cancer, birth defects or other reproductive harm.

SILICOSIS WARNING

Grinding/cutting/drilling of masonry, concrete, metal and other materials with silica in their composition may give off dust or mists containing crystalline silica.



CALIFORNIA PROPOSITION 65 WARNING

Gasoline engine exhaust from this product contains chemicals known to the State of California to cause cancer, birth defects and other reproductive harm.

Safety-Alert Signs

This manual contains Safety-Alert Signs, as defined below, which must be followed to reduce the possibility of improper service damage to the equipment or personal injury. Read and follow all Safety-Alert Signs included in this manual.



NOTE defines an operating procedure, condition, etc. which is essential to highlight that contains useful or important information.



EMERGENCY is used for the identification of safety equipment, first aid, or emergency egress locations.



NOTICE used to convey safety information on labels and signs.



CAUTION is indicative of a potentially hazardous situation which, if not avoided, may result in minor or moderate injury.









WARNING Indicative of a potentially hazardous situations that could result in death or serious injury



DANGER indicates an imminently hazardous situation which, if not avoided, will result in death or serious injury.

⚠ WARNING ⚠ ADVERTENCIA	
	<p>Operation of this equipment may create sparks that can start fires around dry vegetation. A spark arrestor may be required. The operator should contact local fire agencies for laws or regulations relating to fire prevention requirements.</p> <p>El funcionamiento de este equipo puede producir chispas que pueden iniciar incendios en vegetación seca. Un supresor de chispas puede ser necesario. El operador debe comunicarse con las agencias locales de bomberos para las leyes o reglamentos relativos a los requisitos de prevención de incendios.</p>

Some states require that in certain locations arrestors be used on internal combustion engines. A spark arrestor is a device designed to prevent the discharge of spark or flames from the engine exhaust. It is often required when operating equipment on forested land to prevent the risk of fires. Consult the engine distributor or local authorities and make sure that you comply with regulations regarding spark arrestors.

Symbol	Safety Hazard
	Lethal exhaust gas hazards
	Explosive fuel hazards
	Burn hazards
	Rotating parts/crush hazards
	Pressurized fluid hazards
	Hydraulic fluid hazards

Potential hazards associated with the operation of this equipment will be referenced with hazard symbols which may appear throughout this manual in conjunction with safety notes.



Familiarity and proper training are required for the safe operation of this equipment! Equipment operated improperly or by untrained personnel can be dangerous! Read the operating instructions contained in both this manual and the engine manual and familiarize yourself with the location and proper use of all controls.

- **NEVER** operate this machine in applications for which it is not intended.
- **NEVER** operate this machine while under the influence of drugs or alcohol.
- **NEVER** allow anyone to operate this equipment without proper training. People operating this equipment must be familiar with the risks and hazards associated with it.
- **NEVER** touch the engine or muffler while the engine is on or immediately after it has been turned off. These areas get hot and may cause burns.
- **NEVER** use accessories or attachments that are not recommended by AEC. Damage to equipment and injury to the user may result.
- **NEVER** operate the machine with the belt guard missing. Exposed drive belt and pulleys create potentially dangerous hazards that can cause serious injuries.
- **NEVER** leave machine running unattended.
- **DO NOT** run the machine indoors or in an enclosed area such as a deep trench unless adequate ventilation, through such items as exhaust fans or hoses, is provided. Exhaust gas from the engine contains poisonous carbon monoxide gas; exposure to carbon monoxide can cause loss of consciousness and may lead to death.
- **ALWAYS** remain aware of moving parts and keep hands, feet, and loose clothing away from the moving parts of the equipment.
- **ALWAYS** keep hands, feet, and loose clothing away from moving parts of the machine.
- **ALWAYS** read, understand, and follow procedures in the Operator's Manual before attempting to operate the equipment.
- **ALWAYS** be sure operator is familiar with proper safety precautions and operation techniques before using machine.
- **ALWAYS** close fuel valve on engines equipped with one when machine is not being operated.
- **ALWAYS** store the equipment properly when it is not being used. Equipment should be stored in a clean, dry location out of the reach of children.
- **ALWAYS** operate the machine with all safety devices and guards in place and in working order.



Internal combustion engines present special hazards during operation and fueling. Read and follow the warning instructions in the engine owner's manual and the safety guidelines below. Failure to follow the warnings and safety guidelines could result in severe injury or death.

- **DO NOT** run the machine indoors or in an enclosed area such as a deep trench unless adequate ventilation, through such items as exhaust fans or hoses, is provided. Exhaust gas from the engine contains poisonous carbon monoxide gas; exposure to carbon monoxide can cause loss of consciousness and may lead to death.
- **DO NOT** smoke while operating the machine.
- **DO NOT** smoke when refueling the engine.
- **DO NOT** refuel a hot or running engine.
- **DO NOT** refuel the engine near an open flame.
- **DO NOT** spill fuel when refueling the engine.
- **DO NOT** run the engine near open flames.
- **ALWAYS** refill the fuel tank in a well-ventilated area.
- **ALWAYS** replace the fuel tank cap after refueling.
- **ALWAYS** keep the area around the muffler free of debris such as leaves, paper, cartons, etc. A hot muffler could ignite the debris and start a fire.



Poorly maintained equipment can become a safety hazard! In order for the equipment to operate safely and properly over a long period of time, periodic maintenance and occasional repairs are necessary.

- **DO NOT** attempt to clean or service the machine while it is running. Rotating parts can cause severe injury.
- **DO NOT** crank a flooded engine with the spark plug removed on gasoline-powered engines. Fuel trapped in the cylinder will squirt out the spark plug opening.
- **DO NOT** test for spark on gasoline-powered engines if the engine is flooded or the smell of gasoline is present. A stray spark could ignite the fumes.
- **DO NOT** use gasoline or other types of fuels or flammable solvents to clean parts, especially in enclosed areas. Fumes from fuels and solvents can become explosive.
- **ALWAYS** turn engine off and remove key from machine before performing maintenance or making repairs.
- **ALWAYS** handle blades carefully. The blades can develop sharp edges which can cause serious cuts.
- **ALWAYS** keep the area around the muffler free of debris such as leaves, paper, cartons, etc. A hot muffler could ignite the debris and start a fire.
- **ALWAYS** replace worn or damaged components with spare parts designed and recommended by AEC Corporation.
- **ALWAYS** disconnect the spark plug on machines equipped with gasoline engines, before servicing, to avoid accidental start-up.
- **ALWAYS** switch off the power supply at the battery disconnect before adjusting or maintaining the electrical equipment.
- **ALWAYS** keep the machine clean and labels legible. Replace all missing and hard-to read labels. Labels provide important operating instructions and warn of dangers and hazards.

ALWAYS do a thorough inspection of the slings, chains, and hooks before attempting to lift the machine!

OSHA has set forth guidelines which detail the use of Rigging Equipment for Material handling. This guideline is found under

OSHA Standard Number: 1926.251

Please read and follow all guidelines found in this standard.

Removal from service.
Synthetic web slings shall be immediately removed from service if any of the following conditions are present:
 OSHA 1926.251(e)(8)

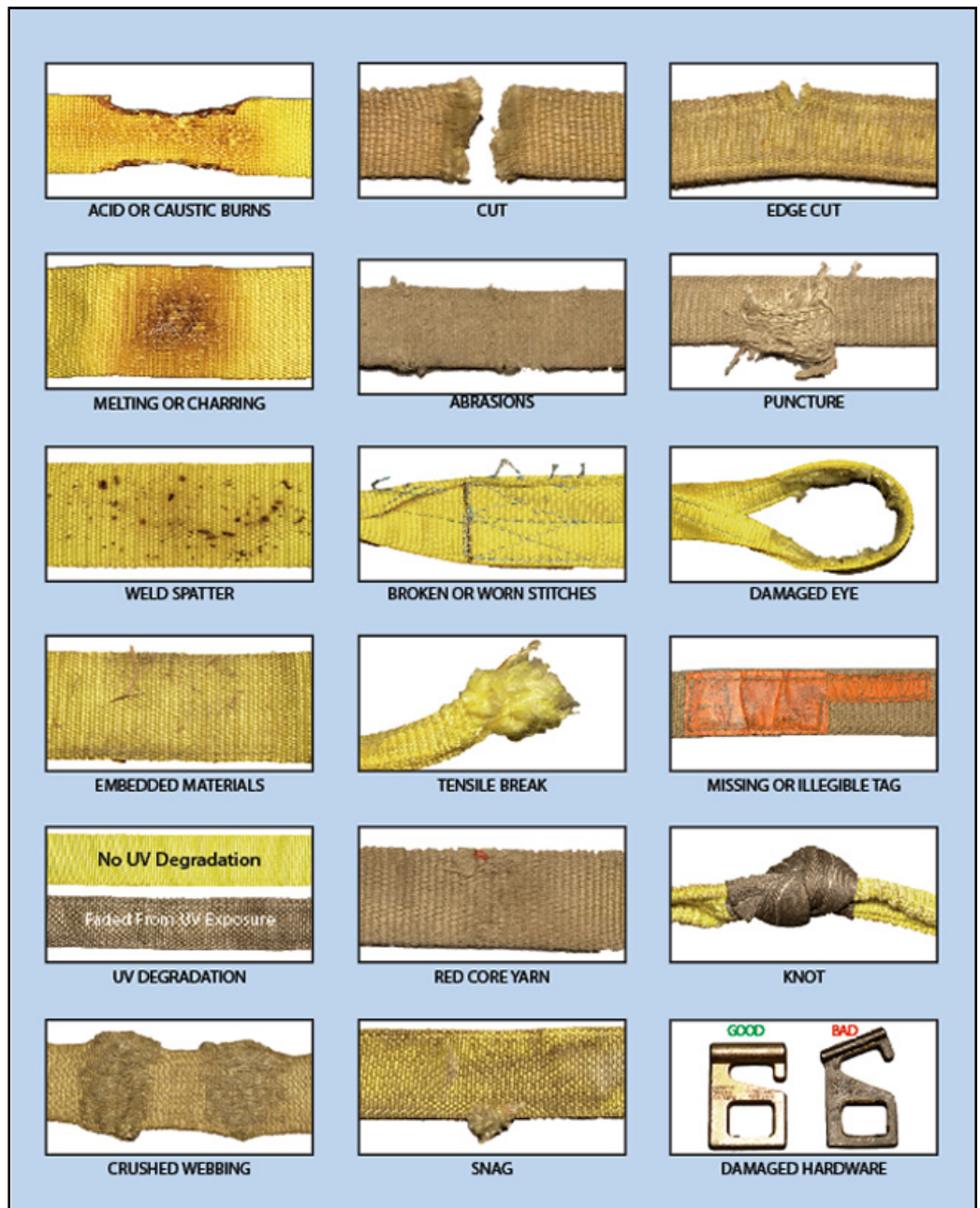

SECTION 1 SAFETY

Lifting Safety

- When lifting the machine, all personnel must be clear of the machine.
- **DO NOT** stand near or under the machine while it is being lifted.

Lifting instructions using a hoist:

- A lifting harness is available for purchase. Part number 075064
- Place slings, chains or hooks through each lifting point on the machine. Use a sling or chains connected to a central lifting device. Ensure that all lifting devices have sufficient weight-bearing capacity.
- **ALWAYS** shutdown engine before transporting.



- Make sure the hitch and coupling of the towing vehicle are rated equal to, or greater than the trailer “gross vehicle weight rating.”
- **ALWAYS** inspect the hitch and coupling for wear. Never tow a trailer with defective hitches, couplings, chains, etc.
- Check the tire air pressure on both towing vehicle and trailer. Trailer tires should be inflated to 50 psi cold. Also check the tire tread wear on both vehicles.
- **ALWAYS** make sure the trailer is equipped with a safety chain.
- **ALWAYS** properly attach trailer’s safety chains to towing vehicle.
- **ALWAYS** make sure the vehicle and trailer directional, backup, brake and trailer lights are connected and working properly.
- DOT Requirements include the following:
 - Connect and test electric brake operation.
 - Secure portable power cables in cable tray with tie wraps.
- The maximum speed for highway towing is 55 MPH unless posted otherwise. Recommended off-road towing is not to exceed 15 MPH or less depending on type of terrain.
- Avoid sudden stops and starts. This can cause skidding, or jack-knifing. Smooth, gradual starts and stops will improve towing.
- Avoid sharp turns to prevent rolling.
- Trailer should be adjusted to a level position at all times when towing.
- Raise and lock trailer wheel stand in up position when towing.
- Place chock blocks underneath wheel to prevent rolling while parked.
- Place support blocks underneath the trailer’s bumper to prevent tipping while parked.
- Use the trailer’s swivel jack to adjust the trailer height to a level position while parked.
- Use tie downs to ensure machine does not move during transportation.

SECTION 1 SAFETY

Transportation Safety



- NEVER allow any person or animal to stand underneath the equipment while lifting.

NOTICE

- **NEVER** transport trowel with float pans attached unless safety catches are used and are specifically cleared for such transport by the manufacturer.
- Before lifting, make sure that the lifting bales are not damaged.
- **NEVER** hoist the trowel more than three feet off the ground with float pans attached.
- Always make sure crane or lifting device has been properly secured to the lifting bales of the equipment.
- **DO NOT** lift machine to unnecessary heights.
- **ALWAYS** shutdown engine before transporting.
- **NEVER** lift the equipment while the engine is running.
- Use adequate lifting cable (wire or rope) of sufficient strength.
- **ALWAYS** tie down equipment during transport by securing the equipment with rope.

This section details the proper technique to utilize the lifting bridle system in a safe manner to install concrete finishing pans.

(NOTE: Images are for illustration purposes only)

Use a lifting sling(bridal) with a capacity of at least 2:1 weight ratio for the equipment being hoisted.

See Accessories page(57) for appropriate lifting harness part number



1. Attach the lifting bridle to the machine shown in section "Lifting Safety"
2. Slowly lift the machine in a safe manner to a height that is required to safely install the pans. This is typically 6"-8" above floor level.



3. Carefully slide the pans under the machine making sure that you are aware of the corners on the blades as they are sharp.
4. Align the pans so that the clips will not be crushed when the machine is lowered back down.
5. Slowly lower the machine down onto the pans. Make sure the blades are going into the proper gaps. (Typically the pans can only be installed one way)



6. Once the machine is on securely on the ground with the pans underneath, remove the lifting bridle from the machine.
7. Start the machine and slowly increase the throttle until the blades begin turning and engaging the pans. The machine is now ready to finish the concrete utilizing the pans.



NOTE: Utilizing the lifting sling(bridal) and the dolly jacks are intended only for site transportation and the installation of pans and blades. DO NOT use them for regular maintenance without the additional use of jack stands to insure stability of the machine.

SECTION 1 SAFETY

Pan Installation, Dolly Jacks

This section details the proper technique to utilize the Dolly Jack system in a safe manner to install concrete finishing pans.
(NOTE: Images are for illustration purposes only)

Use the appropriate set of lifting jacks that are designed for the machine you are lifting.

See Accessories page(57) for appropriate lifting harness part number



1. Attach the front and rear dolly jacks into the machine at the receiving tube locations.
2. Slowly lift the machine in a safe manner to a height that is required to safely install the pans. This is typically 6"-8" above floor level.
3. Carefully slide the pans under the machine, making sure that you are aware of the corners of the blades as they are sharp.
4. Align the pans so that the clips will not be crushed when the machine is lowered back down.
5. Slowly lower the machine down onto the pans. Make sure the blades are going into the proper gaps. (Typically the pans can only be installed one way)
6. Remove the dolly jacks from the machine
7. Start the machine and slowly increase the throttle until the blades begin turning and engaging the pans. The machine is now ready to finish the concrete utilizing the pans.

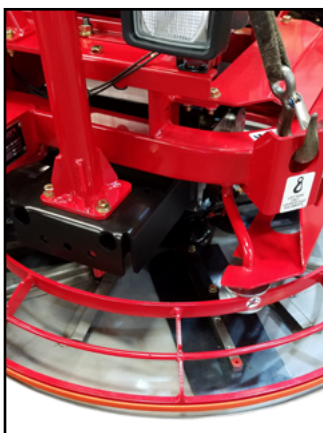

NOTE: Utilizing the lifting sling(bridle) and the dolly jacks are intended only for site transportation and the installation of pans and blades. DO NOT use them for regular maintenance without the additional use of jack stands to insure stability of the machine.

SECTION 2: OPERATION



This machine is built with user safety in mind. However, it can present hazards if improperly operated and serviced. Follow operating instructions carefully.

If you have any questions about operating or servicing this equipment, please contact your Allen Engineering Dealer or AEC Customer Service at 800-643-0095 or 870-236-7751.

- The MSP455X riding trowel is a modern high production machine. Finishing rate will vary depending on the operators skill and job conditions. This riding trowel has ten finishing blades.
- The Super Heavy Duty (SHD) Gearboxes are designed to provide exceptional performance with low maintenance and trouble free use under some of the worst conditions.
- All Allen Engineering MSP455X Riders are equipped with a safety shutdown switch in the seat and the throttle pedal, a low oil warning and a check engine light for added job safety and engine protection.
- Operating time between fuel refills is approximately 2-1/2 to 3 hours with a rotor speeds of 165 to 185 RPM.
- The MSP455X Riders are the most technically advanced riding trowels on the market today. With proper maintenance and use, your riding trowel will provide you with exceptional service and dependability.

Before Starting Procedures

Before starting the riding trowel check for the following:

1. Oil level in the engine and hydraulics.
2. Check for hydraulic leaks
3. Oil level in the riding trowel gearboxes.
4. Fuel level in the fuel tank.
5. Condition of air cleaner on the engine.
6. Condition of the riding trowel arms and blades.
7. Verify that daily maintenance of grease points have been performed.

Starting Procedures

Before starting the riding trowel, refer to Figure 2.1 and Figure 2.2 for location and identification of operational and visual controls pertaining to the operation of the riding trowel.

1. Sit down correctly on the riding trowel seat. DO NOT attempt to start the riding trowel without an operator in the seat.
2. Flip the engine toggle switch up to the ON position. Then push the “push to start” button down until the engine starts, release the button when engine starts. Allow engine to warm up for 5 minutes before operating riding trowel.



Operating the starter for more than 5 seconds can damage the starter or engine. If engine fails to start release the button and wait 15 seconds before operating starter again.



To turn off the riding trowel simply flip the engine toggle switch down to the OFF position and the engine will stop.

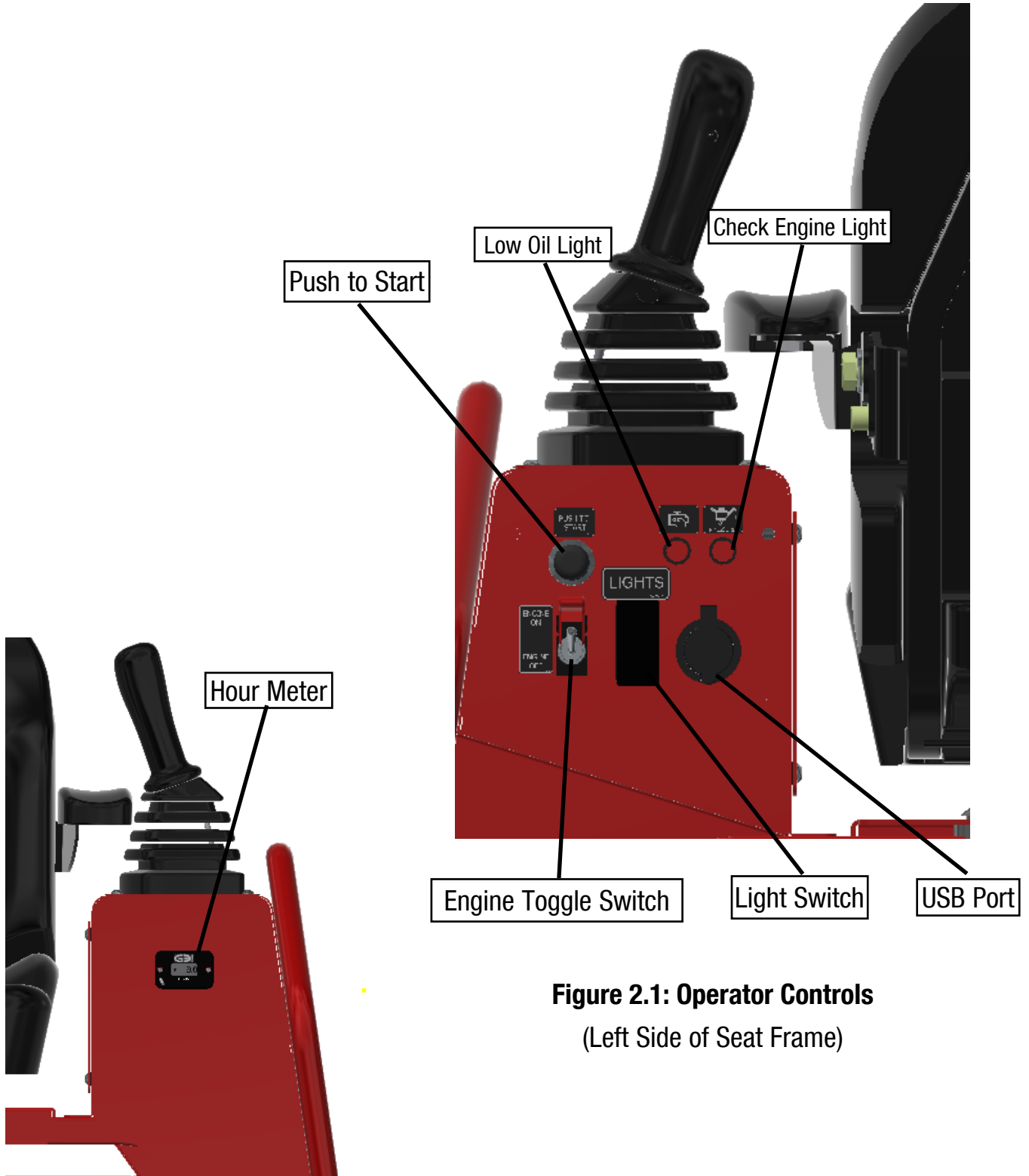

Figure 2.1: Operator Controls
(Left Side of Seat Frame)

Operating The Riding Trowel

To utilize your Allen Engineering **MSP455X** Rider to its fullest capacity the machine should be driven in the direction the operator is facing. This will finish the widest possible area while giving the operator an excellent view of the slab surface about to be troweled. When the machine reaches the end of the slab make a 180 degree turn and repeat the straight line of direction to the other end of the slab. To familiarize a new operator with the riding trowel the following steps should be taken.

! NOTE

All items in this manual are describe from the operator “Sitting On Machine” or **SOM** for short

Location of all Operating Controls

- A. Right Pitch Control
- B. Left Joystick (Forward & Reverse)
- C. Right Joystick (Left & Right, Forward & Reverse)
- D. Left Pitch Control
- E. Right Foot Pedal (Throttle)
- F. Retardant Spray Button
- G. Seat Adjustment

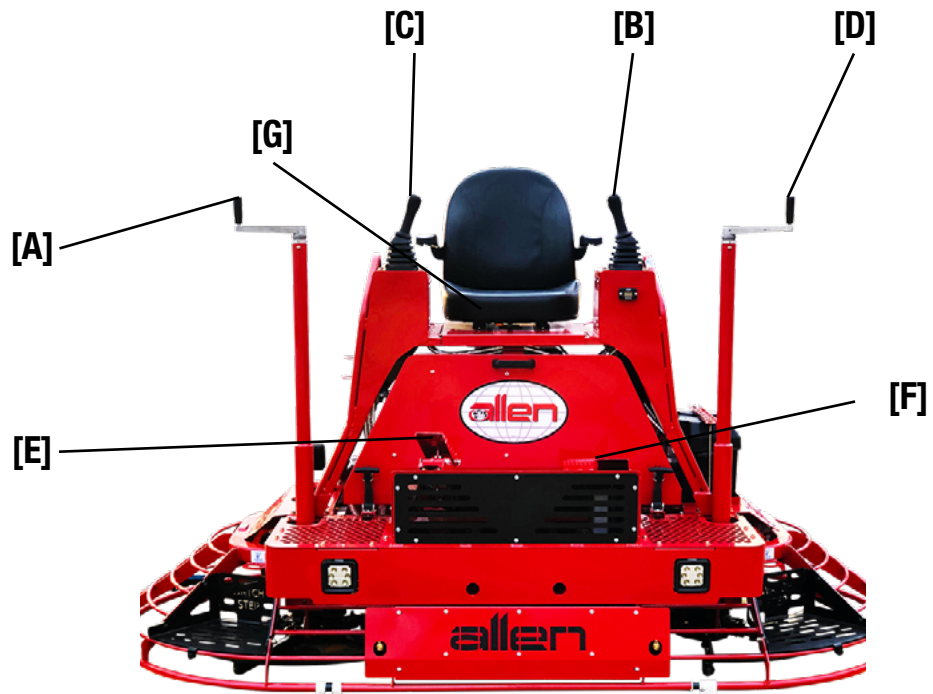

Figure 2.2: Operations Control Components

SECTION 2 OPERATIONS

Trowel Operation

Steering the Riding Trowel

A slight “feathering motion” forward and backward with the left hand joystick is required to move the machine in a straight path to the left. The same feathering motion is required of the left joystick to move to the right.

Figure 2.3: Steering Control Diagram

Position.....	Action
1.....	Forward
2.....	Reverse
3.....	Rotate Clockwise
4.....	Rotate Counter-clockwise
5.....	Sideways - Left
6.....	Sideways - Right

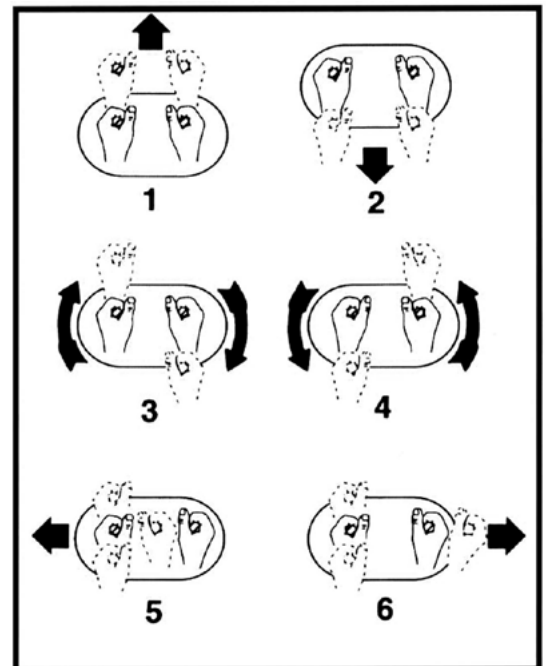

Stopping the Trowel

To stop the trowel's movement, let go of the joysticks [B] and [C]. They will return to their neutral position. Also release pressure on the right foot pedal [E].



New to this machine is the seat kill switch mechanism. If in need of an emergency stop, simply turning the toggle switch off or raising off the seat while holding the right foot pedal down, will stop the engine from running.

Practice Operating the Riding Trowel

With the operator in the seat, show him the functions of the joysticks [B] and [C] and how to start the machine. Refer to Figure 2.2.

A hard level concrete slab with water on the surface is an ideal place for an operator to practice with the machine. For practice pitch the blades up approximately 1/4 inch on the trailing edge. Start by making the machine hover in one spot and then practice driving the machine in a straight line and making 180 degree turns. Best control is achieved at full engine RPM.



After starting the engine, fully engage the throttle. This allows the engine to warm up quicker and also engages the torque converter. At this time the machine's rotors will begin turning.



DO NOT use excessive pressure on the joysticks. Excessive pressure does not increase the reaction time of the machine and can damage steering controls.

Pitch Adjustment

Different pitch angles are needed as you work the different stages of the concrete. Refer to Figure 2.4 table below. When changing or setting pitch (angle of trowel blades), slow the machine down, set the desired degree of pitch on the left side of the machine and then adjust the right side to match.

To increase the pitch, turn the pitch control clockwise "a" us the pitch indicator "b" to adjust pitch equally on both right and left trowel blades.

Figure 2.4: Pitch Adjustment

	Working Conditions of Concrete	Suggested Working Pitch
	① Wet surface working stage	Flat (No Pitch)
② Wet plastic working stage	Slight Pitch	5°
③ Plastic working stage	Additional Pitch	10°
④ Semi-hard working stage	Additional Pitch	15°
⑤ Hard finishing stage (burnishing)	Maximum Pitch	20°

SECTION 3: SERVICE

Periodic Maintenance Schedule

The table below lists basic trowel and engine maintenance. Refer to OEM engine manufacturer's Owner's Manual and Service Manual for additional information on engine maintenance. To service the engine push the seat up from the back and locate the seat's lock latch on the lower right side of the seat. Once the seat is raised push the latch down to lock it in place.

Maintenance Schedule						
Item	Daily	50 Hours	100 Hours	200 Hours	300 Hours	Annually
Check external hardware	✓					
Check hydraulic oil level	✓					
Check hydraulic fittings and hoses	✓					
Check all operational controls	✓					
Grease pressure plates	✓					
Grease steering assembly heim joints	✓					
Check air cleaner element		✓				
Grease driveline bearings and U-Joints		✓				
Inspect drive belts			✓			
Change the engine oil			✓			
Change engine oil Filter				✓		
Change the hydraulic oil				✓		
Change gearbox oil						✓
Inspect battery (fill with water if needed)						✓

Engine Oil

Recommended oil: Kohler PRO 10W-50 Synthetic (2 Qts)

Alternative oil (see page 15 for additional information)

- For general use 10W/30 oil is recommended (2 Qts).

Hydraulic Oil

Replace hydraulic fluid with Hydraulic oil 46 (DTE 25) or equivalent

SECTION 3 SERVICE

Troubleshooting

Area	Malfunction	Possible Cause	Corrective Measure	Ref.
Engine	Engine does not start, or is difficult to start	Battery is discharged	- Add battery fluid - Charge the battery - Replace the battery	
		Battery cable is disconnected	- Connect battery cable	
		Blown fuse	- Replace fuse	
		Bad connection or breakage in the wiring	- Contact your AEC dealer	
		Out of fuel	- Fill fuel	
		Air is in fuel	- Contact your AEC dealer	
		Engine fouled	- Wait a while and try starting again	
		Insufficient or wrong oil	- Fill or change oil	
		Dirty or damaged spark plug	- Clean or replace spark plug	
		Contamination in fuel system	- Contact your AEC dealer	
		Other (other than above)	- Contact your AEC dealer	
	Engine stalls	Out of fuel	- Fill fuel	
		Cold engine	- Warm up the engine	
		Other (other than above)	- Contact your AEC dealer	
	Engine stops abruptly	Out of fuel	- Fill fuel	
		Piston seizure due to insufficient or bad oil	- Contact your AEC dealer	
		Other (other than above)	- Contact your AEC dealer	
	Engine does not stop	Electrical malfunction	- Contact your AEC dealer	
		Other (other than above)	- Contact your AEC dealer	
	Idling is not stable	Insufficient intake air (clogged air cleaner)	- Clean or replace the air cleaner	
		Other (other than above)	- Contact your AEC dealer	
	Poor power or acceleration	Bad fuel	- Change fuel	
		Wrong oil (improper viscosity)	- Change to suitable oil	
		Accelerator (throttle) is not properly adjusted	- Contact your AEC dealer	
		Insufficient intake air (clogged air cleaner)	- Clean or replace the air cleaner	
		Excessive load	- Reduce load	
		Loose drive belt	- Adjust	
	Irregular noise or vibration from or around the engine		- Contact your AEC dealer	
		Excessive oil consumption	- Contact your AEC dealer	
	Engine overheats	Insufficient amount of engine oil	- Fill oil	
		Cooling fan is clogged or blocked	- Clean	
		Other (other than above)	- Contact your AEC dealer	
	Excessive fuel consumption	Clogged air cleaner	- Clean or replace air cleaner	
Other (other than above)		- Contact your AEC dealer		

Troubleshooting Continued

SECTION 3 SERVICE

Area	Malfunction	Possible Cause	Corrective Measure	Ref.
Engine	Black smoke comes out of exhaust	Bad fuel	- Change fuel	
		Clogged air cleaner	- Clean or replace the air cleaner	
		Other (other than above)	- Contact your AEC dealer	
	White or blue smoke comes out of exhaust	Engine oil level is too high	- Adjust the oil level	
Other (other than above)		- Contact your AEC dealer		
Safety Devices	Lamp does not light	Blown bulb	- Replace	
		Blown fuse	- Replace	
		Other (other than above)	- Contact your AEC dealer	
Hydraulic System	Pump does not work	Insufficient or deteriorated hydraulic fluid	- Add or change fluid	
		Other (other than above)	- Contact your AEC dealer	

Trowel Gearbox Maintenance

Check Oil levels in the gearbox daily (every 8 hours) Add oil if the oil level is below the check sight glass.

1. To add oil tilt trowel back and remove the fill plug. Add oil through hole opening. Replace fill plug after proper level has been achieved. DO NOT fill past the fill plug hole opening. Use Kluber GH 6-460 synthetic oil.
2. Each Gearbox has a grease fitting on top cover that must be greased every 300 operating hours. Use only Mobilith SHC 220 Extended pressure grease. **NOTE:** On the left side of the front deck there are grease ports for easy access. Use the two ports on the right, as indicated by the decal, to grease the right and left hand gearboxes. (See second NOTE on pg 43)

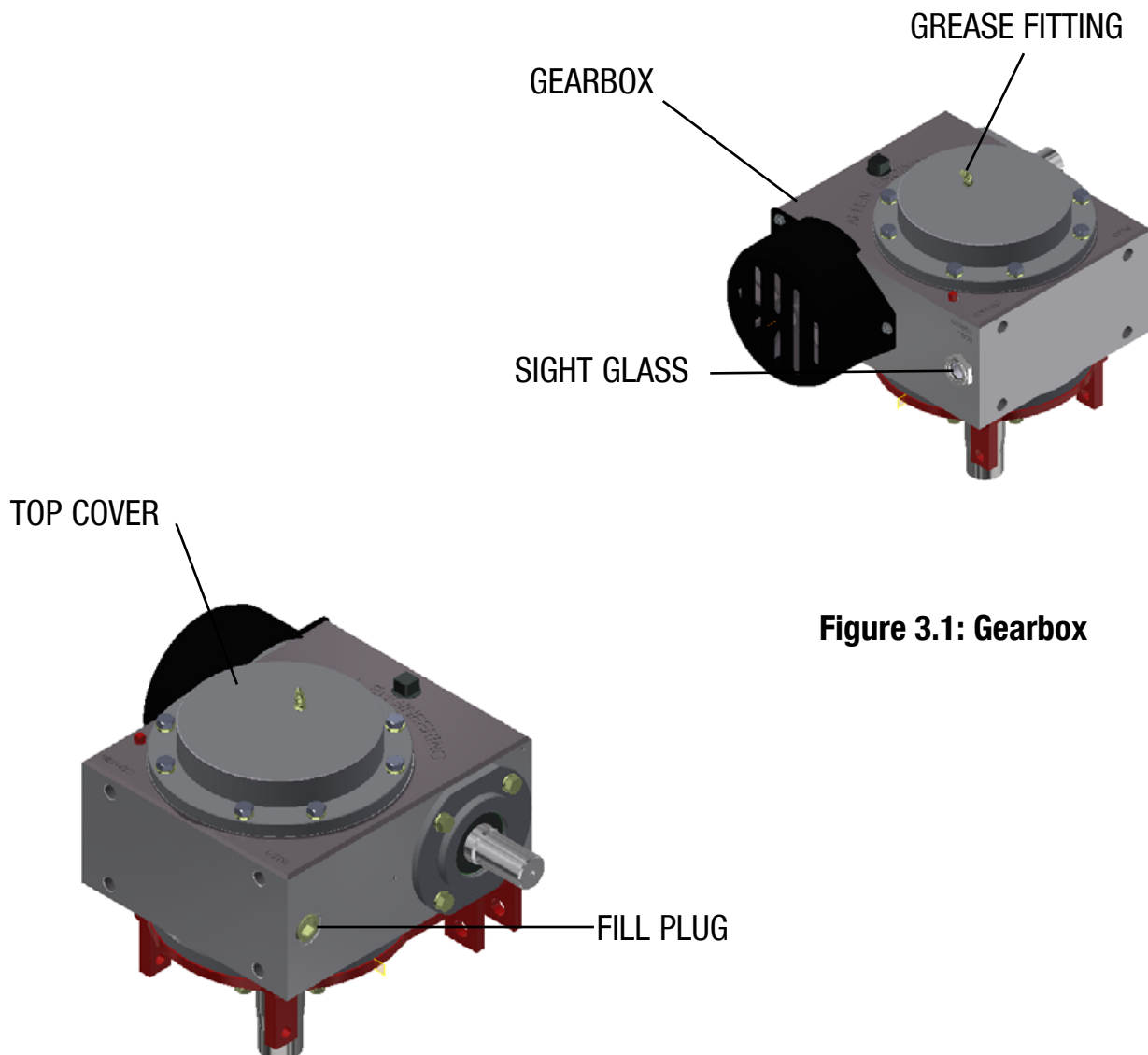
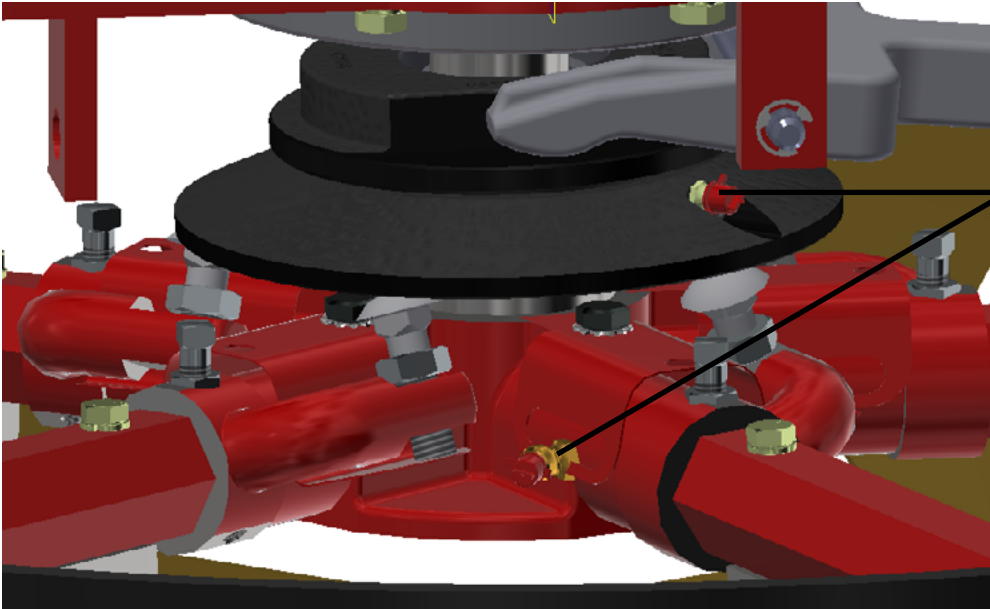

Figure 3.1: Gearbox

(Images are for illustration purposes only)



Grease pressure plates and trowel arms daily.



1. Grease driveline bearings after 50 hours of use.
NOTE: On the left side of the front deck there are grease ports for easy access.
2. Grease U-Joints after 50 hours of use.

NOTE: The greasing tubes have a working pressure of 350 PSI at 75 °F and 210 PSI at 150 °F. When using the front deck grease ports use a manual grease gun and pump grease in a slow uniform manner.



The drive belts **MUST** be free from oil and foreign contaminants to prolong life.

To Replace The Drive Belt:

1. Place the trowel on a flat, level surface with the blades pitched flat.
2. Open the battery box by removing the nuts, and washers on both ends of the battery hold down channel. Disconnect the battery. Refer to Figure 3.2.
3. Disconnect and remove the u-joint assembly closest to driven pulley by removing (4) 1/4"-20 x 5/8" socket head round screws and 1/4" split lock washers on the driveshaft hub. Refer to Figure 3.3.
4. Use a M6x1.0x40 mm bolt to spread apart the pulleys to allow slack in the belt and remove it from the lower and upper pulleys. Refer to Figure 3.4.
5. Replace new belt in opposite order of removal.
6. Apply one drop of blue Loctite No. 242 to the (4X) 1/4"-20 x 5/8" socket head round screws and reassemble with 1/4" split lock washers in opposite order of disassembly.
7. Reconnect the battery. Close the battery box and reassemble the battery hold down channel.

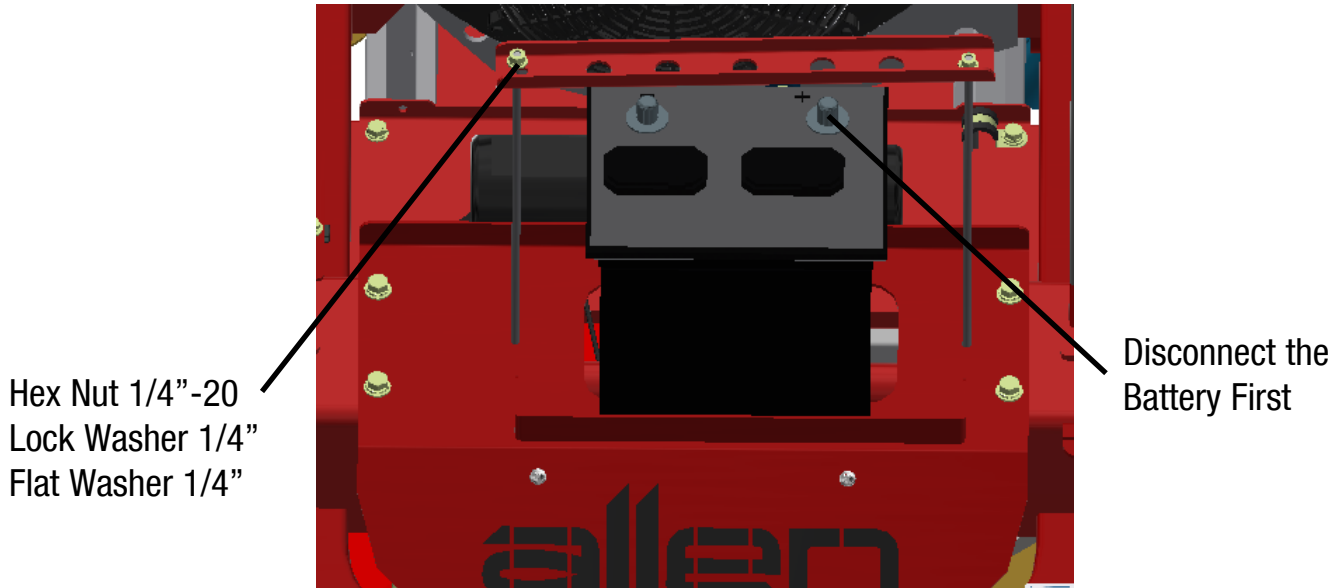

Figure 3.2: Battery

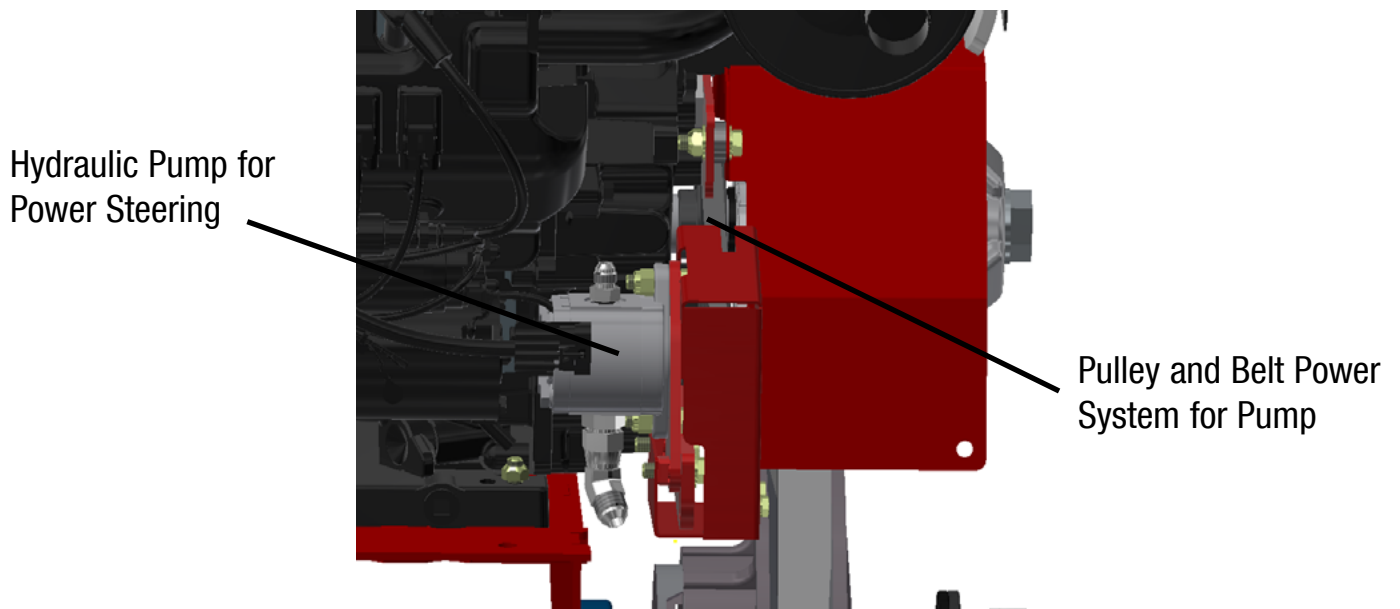
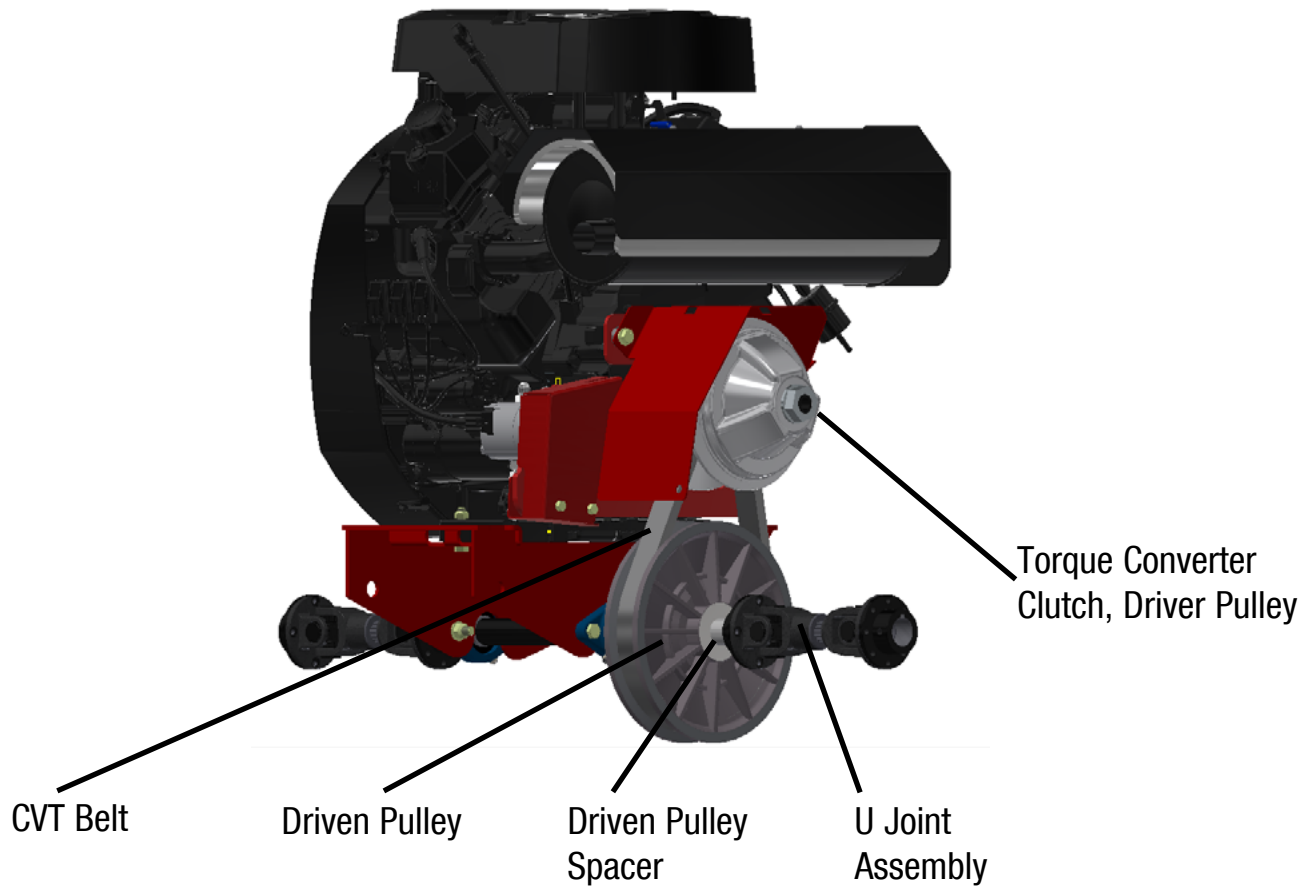

Figure 3.3: Power Assembly



(4) 1/4"-20 x 5/8" socket head round screws and 1/4" split lock washers

Figure 3.3: Power Assembly Continued



M6 x 1mm Hole
Use M6x1x40mm Bolt

Figure 3.4: Pulley Separation

Lift Lever Adjustment Procedure

Damage to and/or replacement of a trowel arm can change the adjustment of the lift lever. This can unbalance the trowel arms and cause the riding trowel to wobble during operation. To operate smoothly the lift lever on all trowel arms must be adjusted the same to ensure that the riding trowel is balanced correctly.

Adjusting the trowel arms is accomplished by using the optional trowel arm alignment jig AEC PN 016863. The service manual that is included with the alignment jig describes in detail the steps to preform this procedure and to check the flatness and straightness of the trowel arms.

The steps below describe the general procedure to remove the trowel arms to be aligned.



Make sure that there is no pitch in the blades before attempting to remove a trowel arm.

1. Block up pressure plate [A] using a wooden block.
2. Remove stabilizer ring from spider assembly.
3. Remove blades from trowel arms.
4. Loosen hex head cap screw [B] and remove it and the external star washer from the spider boss.
5. Remove trowel arms from spider boss with lift levers in place.
6. Clean flats on trowel arm before placing it in the trowel arm jig (PN 016863).
7. Preform the alignment procedures as outlined in the alignment jig service manual (PN 047427).
8. Re-attach trowel arm to spider boss and blades to trowel arms.
9. Tighten down hex head cap screw to secure trowel arm in place.
10. Reattach stabilizer ring (only on available models).

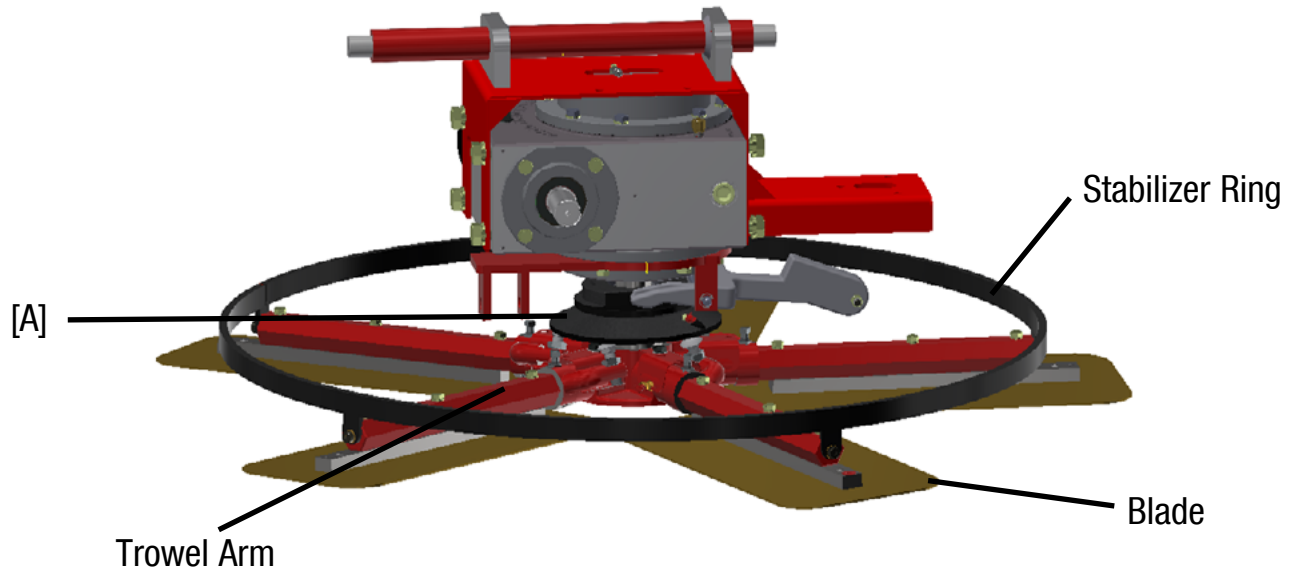

Figure 3.7: Rotor

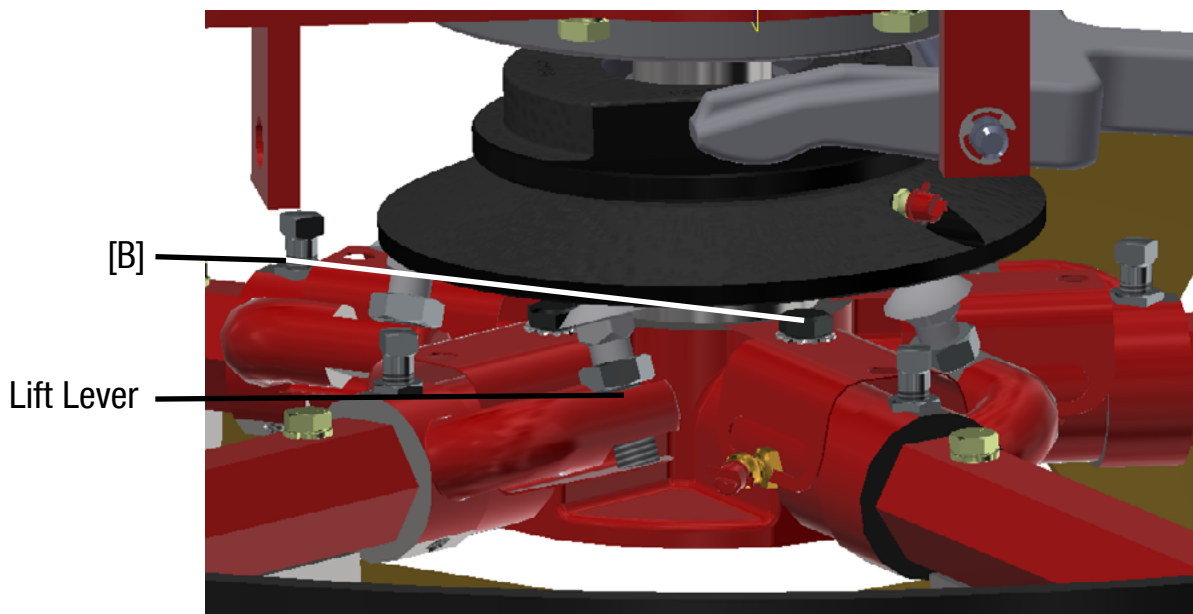

Figure 3.8: Lift Lever Adjustment

Transporting Trowel Procedures

Optional dolly jacks are available for short moves or to aid in servicing the trowel. Install dolly jacks as follows:

1. Inspect dolly jack for serviceability and damage.
2. Place the riding trowel on firm level ground.
3. Tie steering levers to the frame to prevent them from tipping forward when trowel is being lifted.
4. Insert the front dolly jack fully into the holes [K] in the mainframe of the riding trowel. The front dolly jacks are equipped with short lifting tubes while the rear dolly jacks have long lifting tubes.
5. Insert the rear dolly jacks with the long lifting tubes into the holes [L] provided in the rear of the mainframe. The holes in the mainframe are located directly opposite the front holes.
6. Turn jack handles clockwise to lift trowels and counter-clockwise to lower trowel.



The dolly jack lifting system is designed for short moves and to aid in servicing the trowel. It is not a substitute for a towing system or trailer. An optional lifting bridle [N] is available and recommended for lifting the trowel. Attach the bridle to the two lifting points on the trowel. Refer to Figure 3.9 and 3.10.



Secure steering levers to frame to prevent them from tipping forward when the towel is being lifted.

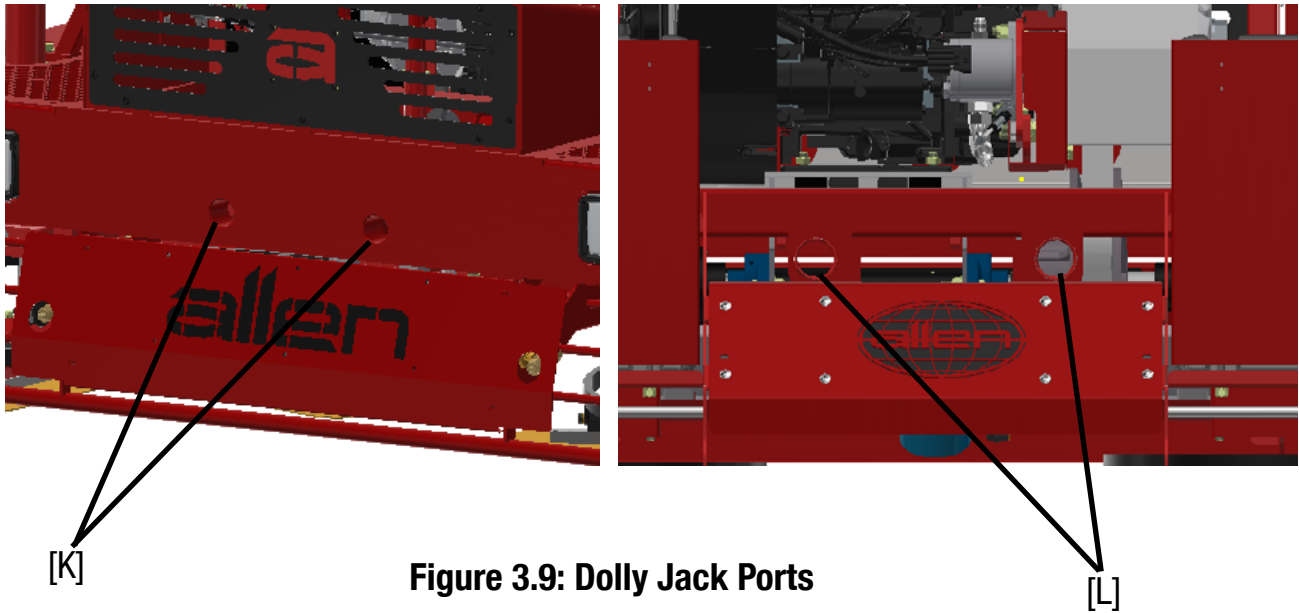

Figure 3.10: Lifting Bridle

Battery Jump Start Procedures

Occasionally it may be necessary to jump start a weak battery. If jump starting is necessary the following procedure is recommended to prevent starter damage, battery damage, and personal injury.



Jump starting a battery incorrectly can cause the battery to explode, resulting in severe personal injury or death. Do not smoke or allow any ignition sources near the battery and do not start a frozen battery.



Electrical arcing can cause severe personal injury. Do not allow the positive and negative cable ends to touch.

1. Use a battery that has the same voltage as the one used with your engine.
2. Attach one end of the positive booster cable (red) to the positive (+) terminal of the booster battery. Attach the other end to the (+) terminal of your engine battery.
3. Attach one end of the negative booster cable (black) to the negative (-) terminal on the booster. Attach the other end of the negative cable to your engine battery.
4. Jump starting in any other manner may result in damage to the battery or the electrical system.



Over cranking the engine can cause damage to the starter. If the starter is engaged for more than 15 seconds wait 5 minutes to let the starter cool.



When using lights or high amperage drawing accessories, idle the engine for a period of 20 minutes to bring the battery to a charging state.

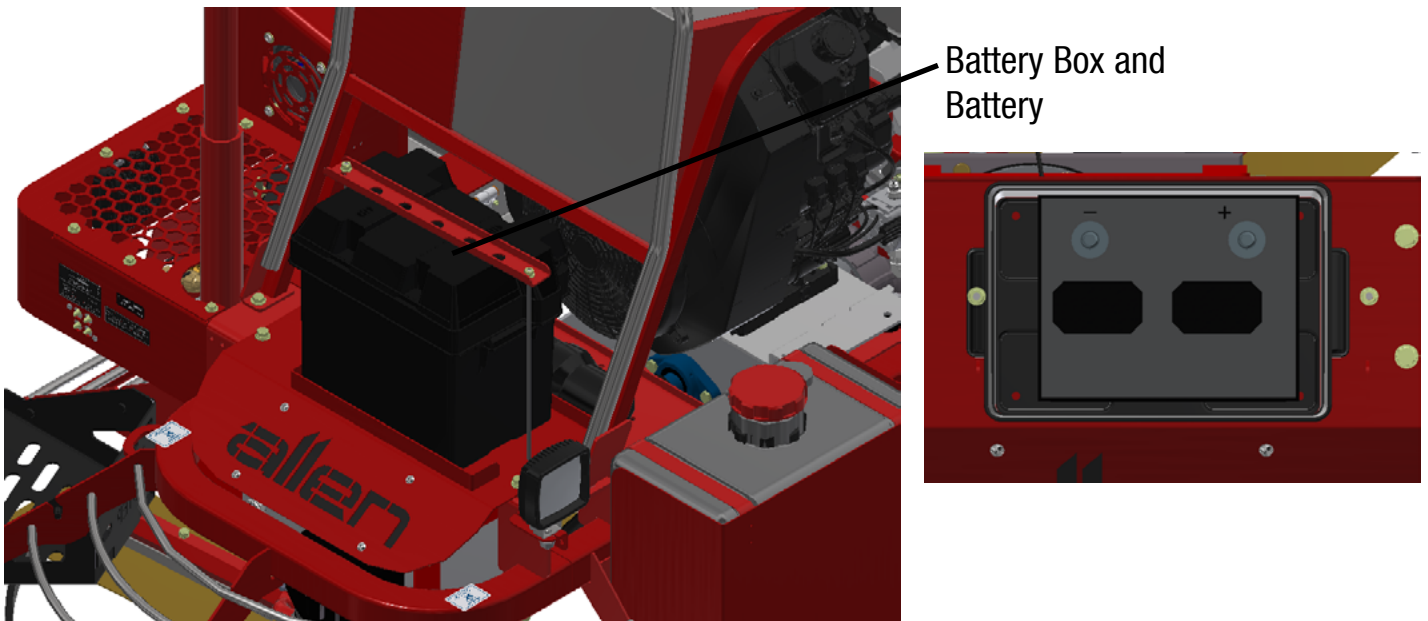

Figure 3.11: Battery Location and Terminals

Why Winterize the Retardant System?

If water is allowed to freeze in the retardant system, serious damage to the hose system and the pump may occur. To prevent freezing in the spray system it is best to completely drain the retardant system of all water.



Failures of this type will void the warranty of the pump



Do not use automotive antifreeze to winterize the retardant system. Antifreeze is highly toxic, and ingestion may cause serious injury or death.

Winterizing the Retardant System Procedure

To properly drain the system perform the following steps:

1. Completely drain the fluid in the retardant tank by disconnecting the hose that is attached to an outlet on the bottom of the tank. Use an appropriate container to catch the fluid.
2. While the tank's hose is disconnected, turn the pump ON and allow the pump to purge the water from the hose system. Then turn the pump OFF.
3. Disconnect all of the hoses that are attached to the pump's inlet and outlet ports. Then turn the pump ON, allowing it to operate until all of the fluid is expelled. Turn OFF the pump once all the water has been expelled. Do not reconnect the hoses at this time.

Be sure to make a note at tank filler as a reminder "Hoses are disconnected for winterizing service." All pump and tank ports must be left open to guard against any freeze damage.

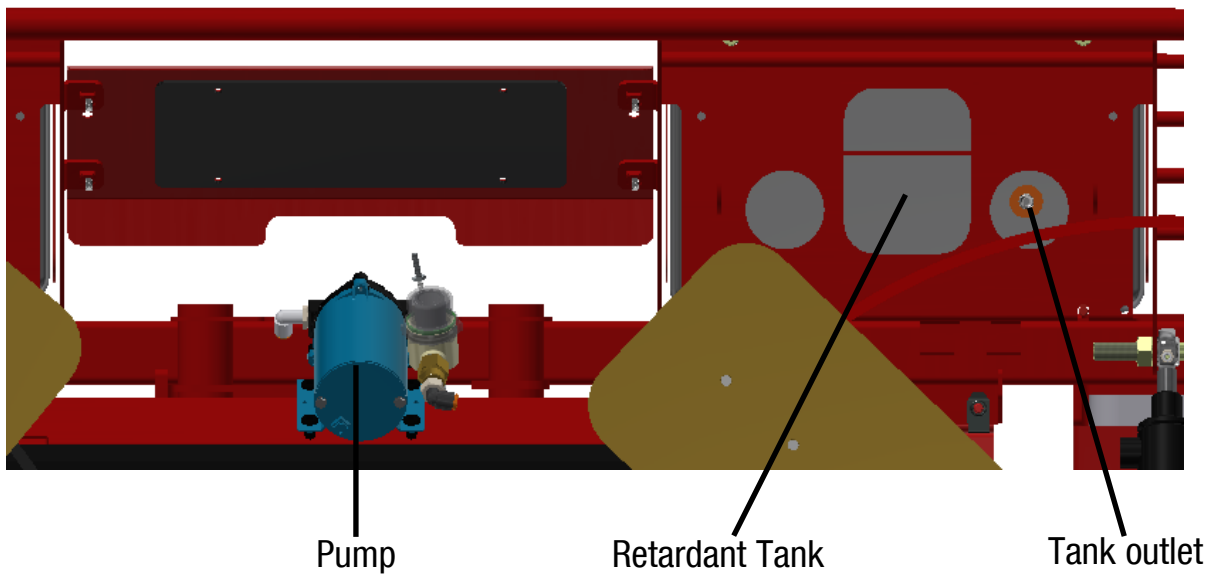

**Figure 3.12: Retardant Tank and Pump
(Underside)**

Machine Cleaning Procedure

When cleaning the machine, please adhere to the following information to ensure proper cleaning and to keep the machine in the best condition possible.

Power Washing Procedure:

NOTICE

- Ensure that the water pressure is below 2000 PSI (14 MPa)
- Always keep the water temperature below 180°F (80°C)
- Use a spray nozzle with at minimum 40° wide spray angle
- Keep the nozzle at least 1 foot (300mm) away from the machine
- Avoid spraying water on the engine and electronic components. Examples include electronic displays, lights, switches, wiring, etc. The electronic components may be damaged if water is sprayed on them.
- Keep a perpendicular angle (90°) when cleaning over a decal.
 - Holding nozzle of a pressure washer at an angle different from 90° may lift the decal from the machine.
- Recommended using a safe cement dissolver, **BACK-SET** or similar, to remove hardened concrete.
- It is **NOT** recommended to use chemicals such as:
 - Muriatic Acid
 - Hydrochloric Acid
 - Hydrofluoric Acid
 - Sulfuric Acid
 - Phosphoric Acid
- To prevent build-up of concrete on the machine, use **BODY GUARD** or similar protection wax.

Filter Cleaning Procedure:

- Remove air filters and blow out with compressed air, **NOT** to exceed 80 PSI.

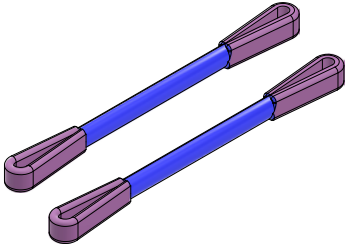

Lifting Bridle, 6,000 lbs Vertical, 4,800 Choker, 6,000 lbs Basket, 3'6" long with 10" eyes

Part Number: 075064



Dolly Jacks are available for MSP riders to make mobilization easier. These tires are foam-filled to help support the added weight of the machine and to help prevent flats. (Comes in set of 2)

Part Number: 039090

Parts Manual

In order to provide a premier experience to our customers, we have moved the “Parts” section out of this manual and placed it in a separate “Parts & Decals Manual”. This will allow us to provide any changes or other important information quicker to you, the customer. See below for ways to access the “Parts & Decals Manual”.

Mobile Device:

Scan this QR code with a compatible device (cellular phone, tablet, etc.)



Computer:

[Link](#)

Mail:

A physical copy of the parts manual can also be mailed to you upon request. Please contact Allen Engineering service department and one can be sent to you.

Allen Engineering
P.O. Box 819
Paragould, Ar.
72451, USA

Phone: 1.800.643.0095 (USA Only) / 1.870.236.7751
Fax: 1.800.643.0097 (USA Only) / 1.870.236.3934

MANUAL REVISION DETAIL

REVISION #	REVISION DATE	REVISION REFERENCE #	REVISION BY
	11/21	Initial Release	MK
A	01/22	Updated Covers	MK
B	04/22	Service & Engine Oil Information	MK
C	06/22	(Service) Greasing Information	MK



AEC FACTORY & HEADQUARTERS

819 S. 5TH STREET
PARAGOULD, ARKANSAS 72450
870.236.7751
800.643.0095 (TOLL FREE (USA ONLY))

MAILING

PO BOX 819
PARAGOULD, ARKANSAS 72451

ALLENENG.COM

CONNECT WITH US ON SOCIAL

